



READY?

In today's healthcare environment, no nurse should be expected to perform hazardous manual handling tasks, even though they are still sometimes called upon to do so. A large percentage of these tasks relate to helping the resident to and from the toilet. For residents who can stand, but cannot necessarily walk, a manual transfer offers very little in the way of activation, participation, mobilization or independence. It is merely the means to an end that benefits neither nurse or resident. It is this situation which is ready for change.

STEDY...

The *Stedy* allows the resident to simply and safely stand by themselves, ready to be transferred to the toilet, eliminating the need for a hazardous manual handling task. It encourages the resident to fully participate in the transfer, improving circulation, stiffness, breathing, digestion and muscle tone. The *Stedy* can create a sense of achievement and a different outlook upon life for many residents, who will then be motivated to use it on a regular basis.

GO!

Once the resident is standing clear of the chair, the nurse positions the flip-down seat supports. This allows the resident to relax and sit comfortably and securely during the transfer to the toilet, eliminating the need for a bulky wheelchair. The *Stedy* allows the nurse to communicate "eye to eye" with the resident for a greater feeling of security. Lightweight and compact, it will pass through the narrowest of doorways and corridors, giving the nurse easier manoeuvrability.

INDEPENDENCE...

When at the toilet, the resident is encouraged to stand, supported by the *Stedy*. The nurse can then safely assist with the adjustment of clothing as required. The resident's independence and dignity is actively promoted as the *Stedy* is used by the resident for support as they lower themselves onto the toilet. This also eliminates the need for a pivot transfer. When ready to do so, the resident is encouraged to stand, while being assisted to dress when necessary, and can be quickly and securely transported. What was once a mundane task now encourages activity from the resident and significantly reduces the physical work load of the nurse.

PRODUCT SPECIFICATIONS

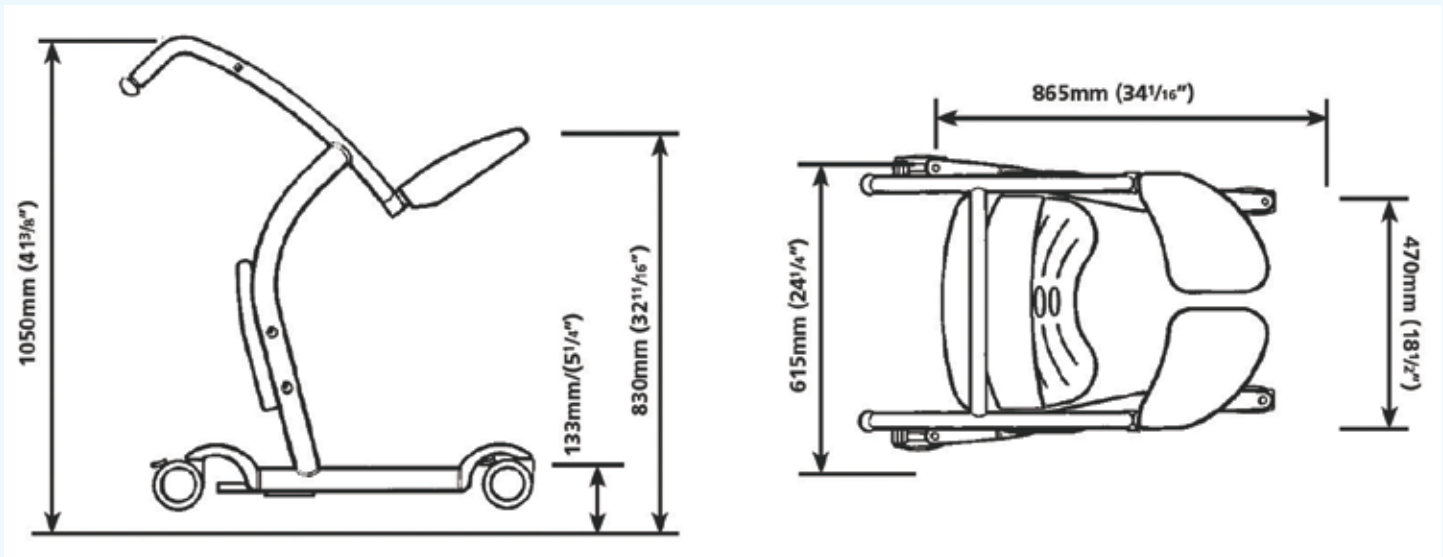

Resident Gallery

Suitable for Barbara



B Barbara, who can support herself to some degree

Please contact ARJO for further information on the Resident Gallery™.

Product information

Product Weight	37 lbs (16.8 kg)
Safe Working Load	264 lbs (120 kg)

Options

For a feeling of extra security, a back support strap may be supplied as an optional extra.



Use only ARJO Designed Parts, i.e. parts specifically designed for the purpose, on equipment and products supplied by ARJO. Our Conditions of Sale specify that ARJO is not liable for injuries attributable to the use of inadequate parts. Continuous development is part of our policy, and we therefore reserve the right to change specifications without notice.

Stedy and Resident Gallery are trademarks belonging to the ARJO group.

ARJO

...with people in mind.

ARJO, Inc.
50 N. Gary Avenue
Roselle, Illinois, 60172
Phone: 800-323-1245
Fax: 888-594-2756
www.arjo.com

GETINGE

GETINGE GROUP is a leading global provider of equipment and systems that contribute to quality enhancement and cost efficiency within healthcare and life sciences. Equipment, services and technologies are supplied under the brands **ARJO** for patient hygiene, patient handling and wound care, **GETINGE** for infection control and prevention within healthcare and life science and **MAQUET** for surgical workplaces, cardiopulmonary and critical care.