

ARJO  
ARJO

Tempo<sup>TM</sup>



# *Operating and Product Care Instructions*



KPX 50550.GB  
Issue 1  
Jan. 2001

---

The vertical and horizontal lines printed in the margins adjacent to the text/illustrations in these instructions are for ARJO use only and should be disregarded by the reader.

Some of the information contained in these instructions may become outdated, due to improvements made to the product in the future. If you have any questions regarding these instructions or your lifter, please contact ARJO or their approved distributor.

*The policy of ARJO is one of continuous development, and therefore reserve the right to change specifications without notice.*

*ARJO strongly advise and warn that only ARJO Company Designated Parts, which are designed for the purpose, should be used on equipment and other appliances supplied by ARJO, to avoid injuries attributable to the use of inadequate parts.*

*The ARJO Company's Conditions of sale make specific provision confirming no liability in such circumstances.*

*'Tempo' and 'Flites' are trademarks of the ARJO Group*

# Contents

---

<b>SECTION</b>	<b>Page No.</b>
<b>Foreword</b> .....	4
<b>Safety Instructions</b> .....	5
<b>Product description/function</b> .....	6-12
Parts referred to in this manual .....	6
Slings .....	8
Control Handset.....	10
Dual Control panel .....	10
Emergency stop button (red) .....	10
Reset button (green) .....	10
Automatic cutout .....	11
Automatic stop function .....	11
System failure lower override .....	11
System failure wind down facility .....	11
System cut-out switch .....	11
Battery discharge indicator.....	12
Service indicator.....	12
Chassis castor Brakes .....	12
Adjustable width chassis legs.....	12
Jib and spreader bars .....	12
<b>Using your <i>Tempo</i></b> .....	13-20
Before approaching the patient .....	13
Power opening 'V' chassis.....	13
Using the 4 point spreader bar.....	13
To lift from a chair .....	13
To lift from a bed .....	15
To raise from the floor .....	16
At the toilet .....	18
Powered Patient Positioning spreader bar (if fitted) .....	19
Patient positioning function cut out fuse...	20
Care of your Powered Patient Positioning spreader bar .....	20
Patient scale (if fitted) .....	20
<b>Lifter Battery charging</b> .....	21-22
Warnings for charging .....	21
General safety Practices for Batteries .....	21
<b>Care of your <i>Tempo</i></b> .....	23-25
Sling Care and Cleaning.....	23
Lifter Care and Cleaning .....	23
Periodic Testing.....	24
Service Advice .....	24
<b>Labels</b> .....	26
<b>Technical Specification</b> .....	27-29
Lifter Dimensions.....	29

# Foreword

---

Thank you for purchasing ARJO equipment

Your *Tempo* is part of a series of quality products designed especially for hospitals, nursing homes and other health care uses.

We are dedicated to serving your needs and providing the best products available along with training that will bring your staff maximum benefit from every ARJO product.

Please contact us if you have any questions about the operation or maintenance of your ARJO equipment.

The touch panel label on the dual control panel displays several instruction symbols. The letter (i) shown on the open book icon indicates 'information', and is an instruction to always read the operating instructions before use. (See fig. 1).

The expected operational life of the *Tempo* is 10 years, providing it has been regularly serviced and maintained as recommended in these instructions.

The expected operational life of the consumable parts e.g. batteries, slings etc. is dependent on usage (see also 'Care of Your *Tempo*' section).

All references to the patient in these instructions refer to the person being lifted, and reference to the attendant refer to the person who operates the lifter.

References to left and right of the lifter in these instructions are as viewed from the rear of the *Tempo*, i.e. viewed from the dual control panel (see fig. 1)

Lifting operations in these instructions are described as if lifting a patient from a chair, the same operations can be performed effectively when lifting a patient from a wheelchair or sitting position on a bed, although a second attendant should support the patient if the patient lacks sitting balance.

All operations in these instructions are described as if the attendant were using the control handset. Each operation described can be controlled using the control handset and/or the dual switch panel, situated at the rear of the mast.

# Safety Instructions

---

Before using your *Tempo*, familiarise yourself with the various parts and controls as illustrated in fig. 1, and other illustrations, then please read this manual thoroughly in its entirety before using your *Tempo*. Information in the manual is crucial to the proper operation and maintenance of the equipment, and will help protect your product and ensure that the equipment performs to your satisfaction. Some of the information in this booklet is important for your safety and must be read and understood to help prevent possible injury. If there is anything in the manual that is confusing or difficult to understand, please call ARJO Ltd or their appointed distributor (the telephone number appears on the last page of this manual).

Symbols used adjacent to the text in these instructions:-



**Danger:** Means:- electrical hazard warning, failure to understand and obey this warning may result in electrical shock.



**Warning:** Means:- failure to understand and obey this warning may result in injury to you or to others.



**Caution:** Means:- failure to follow these instructions may cause damage to all or parts of the system or equipment.



**Note:** Means:- *this is important information for the correct use of this system or equipment.*

This product has been designed and manufactured to provide you with trouble free use, however, this product does contain components that with regular use are subject to wear.



**Warning:** SOME OF THESE PARTS ARE SAFETY CRITICAL TO THE OPERATION OF THE LIFTER AND WILL NEED EXAMINING AND SERVICING ON A REGULAR BASIS AND MUST BE REPLACED WHEN NECESSARY.

See also “Care of your Tempo” section.



**Warning:** Use only ARJO slings that have been specifically designed for the *Tempo*.



**Warning:** Do not overload the *Tempo* beyond the approved lifting capacity.

The *Tempo* may be used on gentle slopes with caution.

Do not attempt to manually lift the complete lifter.



**Caution:** Although manufactured to a high standard the *Tempo* and accessories should not be left for extended periods in humid or wet areas.

Do not under any circumstances spray the *Tempo* or accessories (excluding slings or ARJO approved wet environment equipment - if fitted) with water e.g. under the shower.



**Warning:** It is advisable to familiarise yourself and understand the operation of the various controls and features of the *Tempo* and ensure that any action or check specified is carried out before commencing to lift a patient.



**Warning:** The ARJO *Tempo* has been designed as a mobile lifter for raising and transporting patients in hospitals and care facility environments, and should only be used for this purpose.

This product is intended to be operated entirely by an attendant. No functions regarding the control of this product should be performed by the patient. A second attendant may be required with certain patients.

# Product Description/Function

Parts referred to in this manual

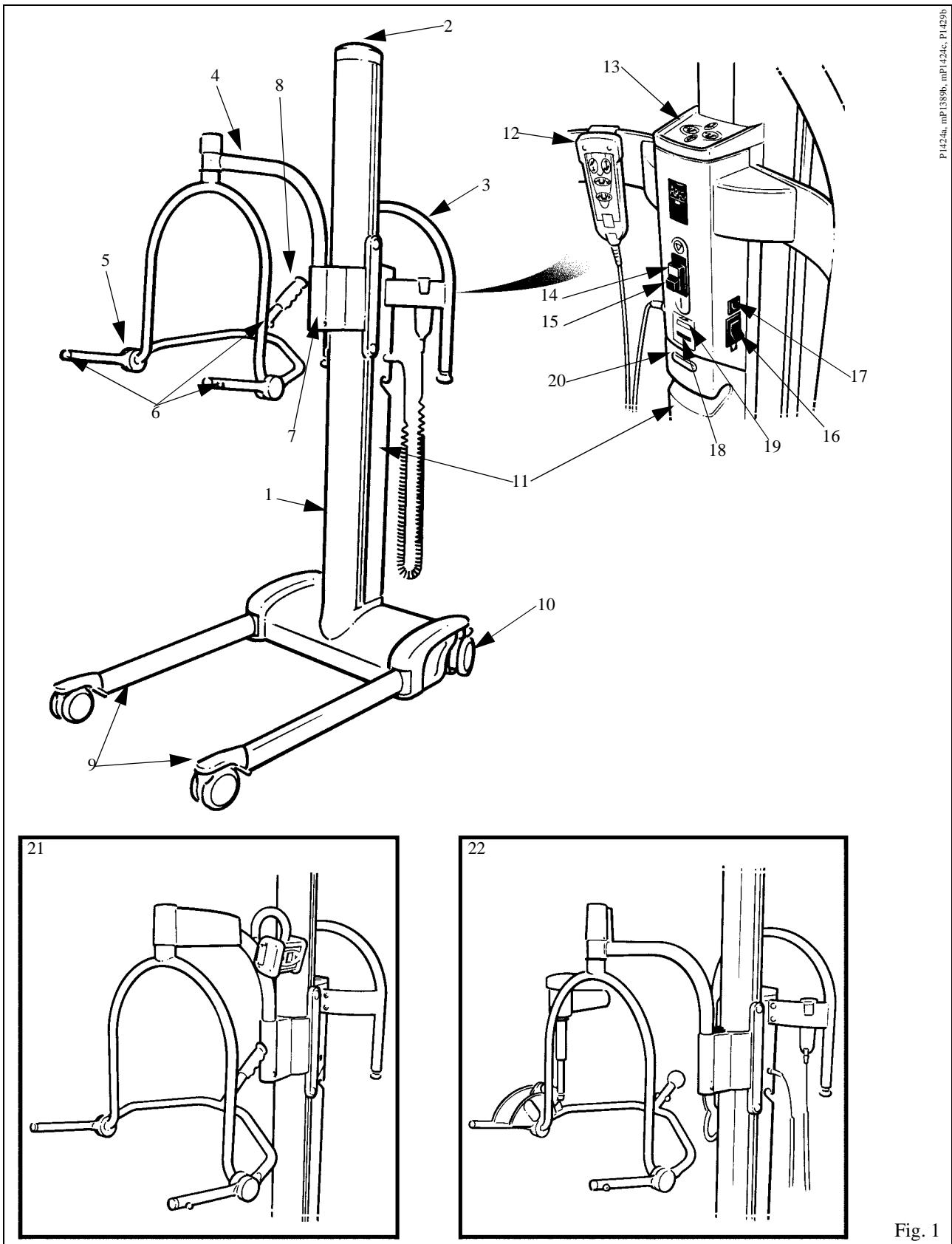

Fig. 1

# Product Description/Function

---

*fig. 1 Key*

1. Mast
2. Mast top cover
3. Manoeuvring handle
4. Jib
5. Spreader bar
6. Sling attachment lugs
7. Jib mounting carriage
8. Spreader bar positioning handle
9. Adjustable width chassis legs
10. Braked castors (rear)
11. Battery pack
12. Control handset
13. Dual control panel
14. Emergency stop button
15. Reset button
16. System failure lower override
17. System 'cut out' switch
18. Battery discharge indicator
19. Service indicator
20. Battery release button
21. Scale Jib (if supplied)
22. Jib with powered patient positioning spreader bar (if supplied)

# Product Description/Function

---

## Slings

- **Note:** All Tempo slings will support 190kg/420lbs), note: the extra extra large sling will support 200 kg (440 lbs) all slings are coded for size by having different coloured edge binding as follows:  
Brown - Extra small - XS  
Red - Small - S  
Yellow - Medium - M  
Green - Large - L  
Blue - Extra Large - XL  
White - Extra Extra Large

A circular label is fitted to the lifter jib for quick colour to size reference (see “Labels” section).

A range of special purpose slings are available as accessories, for these or for special size slings, contact your ARJO representative.



**Warning:** Only use ARJO supplied slings that are designed to be used with *Tempo*. The sling profiles illustrated (see fig. 2) will help to identify the various ARJO slings available.

If ARJO *Flites* (disposable slings) are to be used with the *Tempo*, then always refer to the separate operating instructions for ARJO *Flites*, (literature reference part No. MAX01720), as well as these instructions before using.



**Warning:** ARJO slings with head support have two pockets at the head section which should contain plastic reinforcement pieces during use. Always ensure these reinforcement pieces have been inserted into the sling pockets before using the sling.



# Product Description/Function

*ARJO standard sling profiles that can be used with the Tempo*

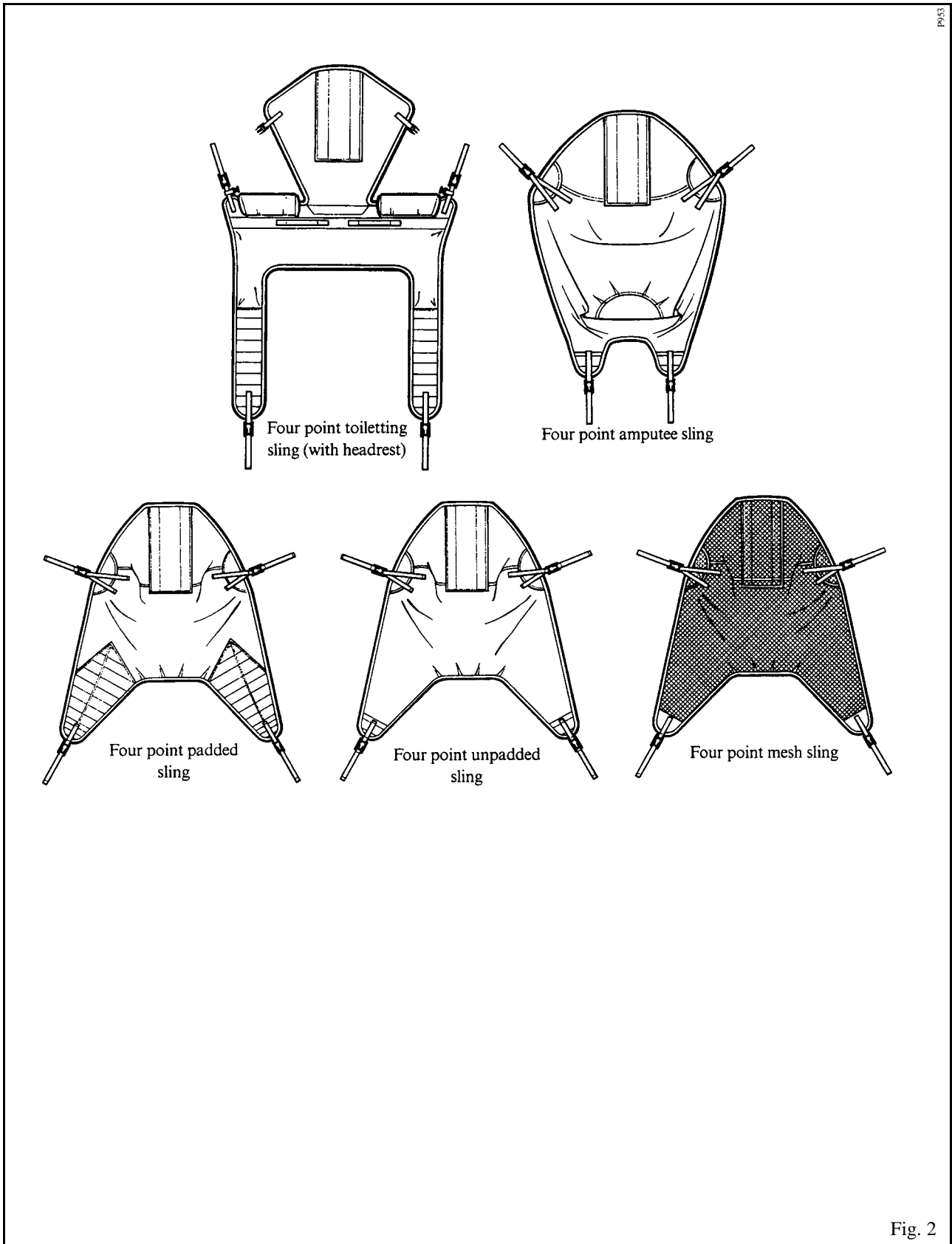

# Product Description/Function

## Controls and Features

**Control Handset:-** (see fig. 3) Raising and lowering the jib and opening and closing the chassis legs, is achieved by pressing the appropriate button on the control handset. Note: icons with direction arrows are printed on each button for quick reference.

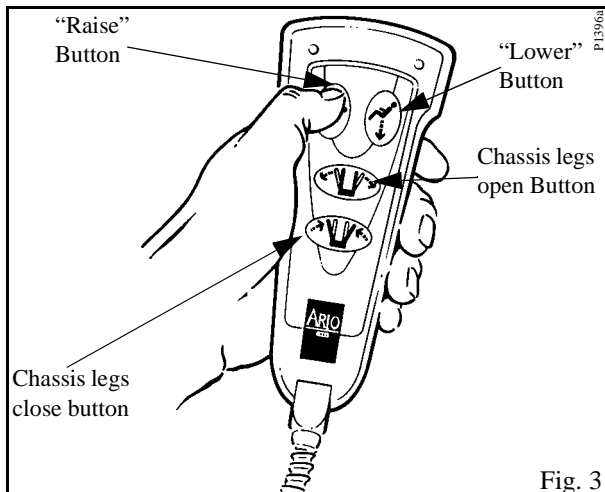

Fig. 3

If pressure is released during any function powered motion will cease immediately. Do not drop the handset into water, e.g.: bath etc., although if this does happen inadvertently no harm will come to patient or attendant.

When not in use, the handset can be conveniently kept ready for use by hooking it over the handle support at the rear of the mast.

**Dual Control Panel:-** (see fig. 4) An additional feature fitted to the *Tempo*, is a mast mounted dual switch panel which operates in parallel with the control handset enabling powered operations to be controlled from the lifter mast as well as remotely, using the handset. As with the handset, icons with direction arrows are printed on each button for quick reference.

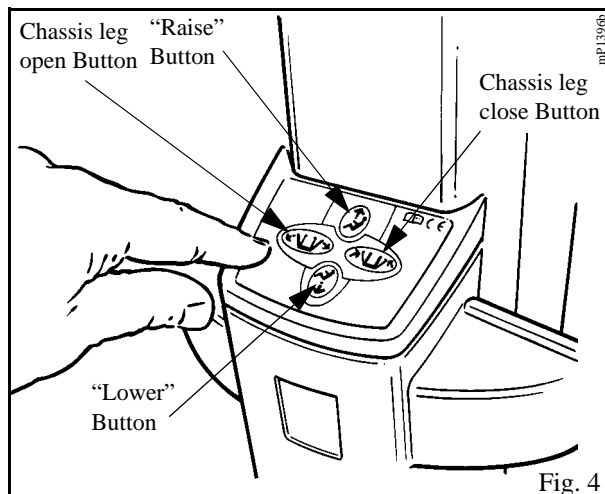

Fig. 4

**Emergency Stop Button (Red):-** (See fig. 5) If, in an emergency, you have to immediately stop any powered movement, (other than by releasing pressure on the control handset button or dual switch panel button), press the "emergency stop button", situated on the rear of the mast.

Once the emergency stop button has been operated, the green reset button will have to be re-engaged by pressing it in, before any powered movement can be utilised.

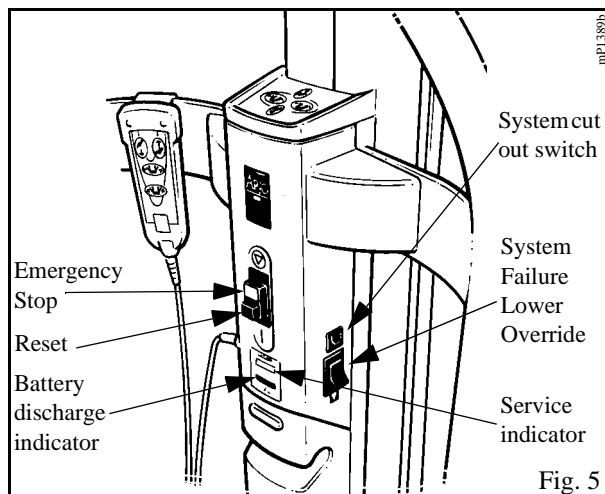

Fig. 5

**Reset button (green):-** (See fig. 5) Adjacent to the emergency stop button. It is used to reset the 'power on' condition, once the emergency stop button has been operated, also used to reset if the automatic overload fuse has operated, indicated by the reset button projecting outwards slightly. If the fuse has operated and once reset, operates again, withdraw the lifter from use and contact ARJO Service department or their appointed distributor.

# Product Description/Function

**System Failure Lower Override:-** (See fig. 5) This can be used in the event of main control failure. In the unlikely event that the control handset or dual switch panel fails to operate the lifter, with a patient still supported by the sling or stretcher, provision for lowering has been made, using the “System Failure Lower Override switch”, situated on the right hand side of the controls console, a green and white identification label is positioned near the switch, for quick and easy recognition. If pressure is released from the switch during use, lowering will stop.



**Warning:** The Lower Override switch will only operate while the green reset button is in. Only use this switch in an emergency, do not use it for normal function lowering.

**System Failure Wind Down Facility:-** (see fig. 6) If the electrical power fails completely due to battery power loss or other electrical malfunction, the jib can be lowered, by firstly, removing the battery pack, then using a coin or screwdriver slacken and remove the screw that retains the mast top cover. Slightly lift the rear side of the top cover

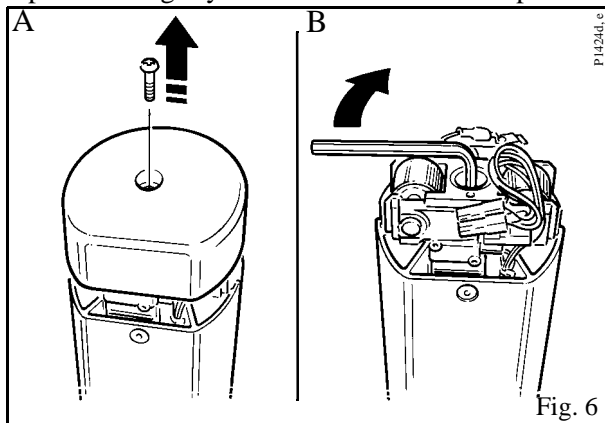

approximately 5 mm (3/16 in), slide the cover forwards then lift it off the mast. Identify and remove the Allen key (hexagon wrench) located inside the mast. Identify the hexagonal hole in the shaft centre inside the mast and using the Allen key (wrench) turn the shaft clockwise to lower the patient.

- Note:** One full clockwise rotation of the shaft lowers the mast jib by approx. 6mm (1/4 in).



**Warning:** If the wind down facility has to be utilized always ensure that suitable and safe measures are taken to gain access to the top cover.

Hold the Allen key (hexagon wrench) securely into the shaft and do not release hand contact with the key (wrench) to ensure control is maintained during the lowering procedure.

Once the patient has been lowered and removed from the lifter ensure the components are re-assembled by reversing the above procedure.

If the system failure lower override switch or wind down facility has to be operated the lifter must then be withdrawn from use immediately and the ARJO Service Department or their appointed distributor contacted.

**System Cut-Out Switch:-** (See fig. 5) If the lifter functions fail to operate when pressing the buttons on the control handset or dual switch panel.

Check that the “green” reset button is pressed in and check that the battery pack is in a good state of charge, if the lifter still fails to operate, check the system cut out switch, situated on the right hand side of the controls console above the lower override switch. If the cut-out has operated, the switch will protrude from its mount, press the switch in to reset.



**Warning:** If the system cut out switch operates again withdraw the lifter from use and contact ARJO Service Department.

**Automatic cut out:-** (not an operator control but a function built into the lifter electronics)

If the lifter is inadvertently overloaded (trying to lift a patient heavier than permitted), an automatic ‘cut out’ operates to prevent the lifter lifting a load in excess of one and a half times the maximum rated load; this will stop the lift motion automatically.

If this occurs, when pressure is released from the lift button on the handset or dual control the electronics will, after a short delay, reset and enable the patient to be lowered only by pressing either lower button. Remove the patient from the lifter.

**Automatic stop function:-** (not an operator control but a function built into the lifter electronics)

Great care should be taken not to lower the spreader bar, or stretcher onto the patient or any other obstruction, but if this should happen inadvertently the motor will continue to run, but downward movement will be held by the obstruction. If this occurs release pressure from the ‘lower’ button immediately, operate the ‘raise’ button until clear, then remove the obstruction.

# Product Description/Function

**Battery Discharge Indicator:-** (See fig. 1&5) Is a small LED display which shows the charge condition of the lifter battery. (See also 'Battery Charging Section' for complete description).

**Service Indicator:-** (See fig. 1&5) Is a small LCD display which shows the total duration of powered operation (in hours) of the lifting and lowering procedure. This is primarily intended as an aid to service engineers.

**Adjustable width chassis legs:-** (See fig. 7) By operating the appropriate button on either the control handset or dual control panel on the lifter the chassis legs can be opened to any variable width. When pressure is released from the button, movement will stop and the chassis legs will remain securely in position. Always transport the chassis legs in the narrow (closed) position.

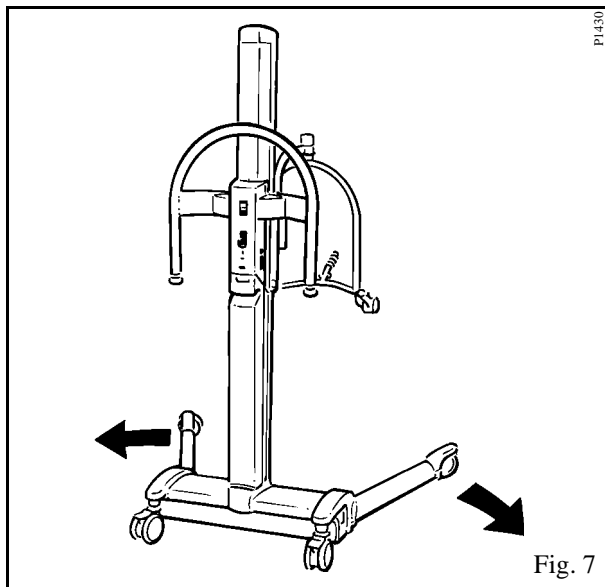

**Chassis castor Brakes:-** (See fig. 8) The chassis rear castors have brakes which can be foot operated if required, for example, when leaving the patient unattended, or to keep the *Tempo* in position.

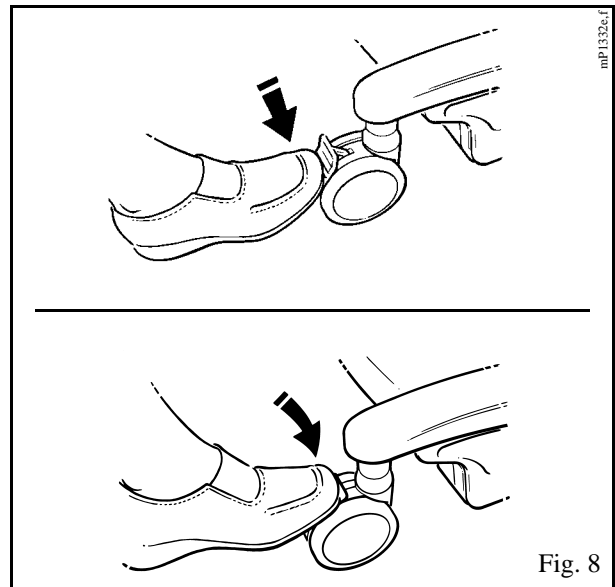

**Jib and spreader bars:-** (see fig. 1) Your *Tempo* may be supplied with a permanently attached four point spreader bar (standard reach or with an extension). Alternatively it may be fitted with a Powered Patient Positioning spreader bar (P.P.P.) any of these options maybe supplied with or without a patient weigh scale.

Although the illustrations in this manual show the standard four point spreader bar being used, all operations can be performed in exactly the same way with the P.P.P. or jibs with extensions.



**Warning:** The maximum permitted patient weight maybe reduced with jib extensions etc. see "Technical Specification" section for details.

# Using your *Tempo*

## *Before Approaching the Patient:-*

Ensure the battery pack supplied is fully charged before use (for charging, see instructions in “Lifter Battery Charging” section). When the battery pack is fully charged remove it from the charger unit and insert it into the battery position of the *Tempo* situated at the rear of the mast (see fig. 1) by firstly, locating the recess across the bottom of the battery with the protrusion at the bottom of the battery position, then pivot the battery into position until the retaining catch operates. Electrical connection will be made automatically.

Ensure the green reset button (situated on the control console below the dual control panel) is pressed in (see fig. 5)

Ensure a selection of sling types and sizes are easily available for all types of lift likely to be encountered when using the ARJO *Tempo*.

The attendant should always tell the patient what they are going to do, and have the correct size sling ready. Where possible, always approach the patient from the front.



**Warning:** To ensure maximum patient comfort, do not allow the patient to hold onto the spreader bar.

If required, the chassis legs may be opened to go around a chair or wheelchair.

## *Powered opening ‘V’ chassis:-*

Select the appropriate button on the control handset or dual switch panel and keep it depressed until the required width is achieved. To close, press the appropriate button, movement will stop if pressure is released, whether opening or closing.



**Warning:** When opening or closing the legs on a powered chassis, care must be taken not to allow anyone to stand in the way of the moving chassis legs.

Transport the *Tempo* with the chassis legs in parallel (closed) position only.

## *Using the 4 Point Spreader Bar*

### *To Lift from a Chair*

Place the sling around the patient so that the base of his/her spine is covered, and the head support area is behind the head. Pull each leg piece under the thigh so that it emerges on the inside of the thigh. (See fig. 9).

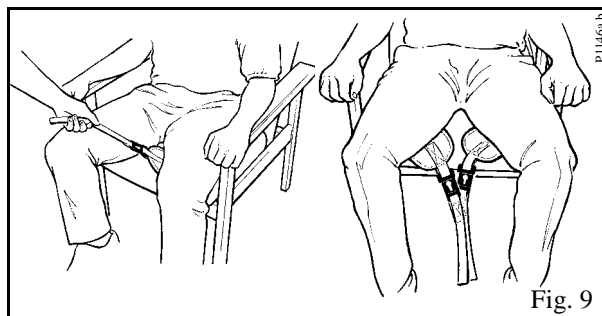

Ensure the positioning handle on the spreader bar is facing away from the patient, and that the wide part of the spreader bar is at, or just below shoulder level. (See fig. 10).

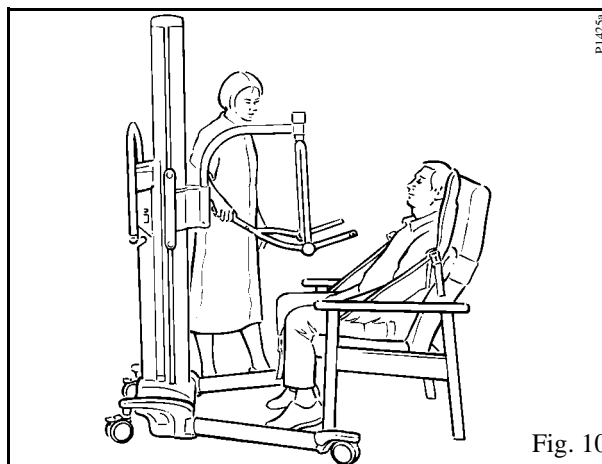

Ensure that the *Tempo* is close enough to be able to attach the shoulder clips of the sling to the spreader bar. To accomplish this you may have to put the patients feet on, or over the chassis.

Once the *Tempo* is in position, attach the shoulder strap attachment clips to the pegs on the spreader bar. (See fig. 11).

- Note:** The chassis rear castors have brakes which can be foot operated when required (see fig. 8). Do not apply the castor brakes at this stage, as the position of the patient will adjust to his/her own centre of gravity when lifted.

# Using your *Tempo*

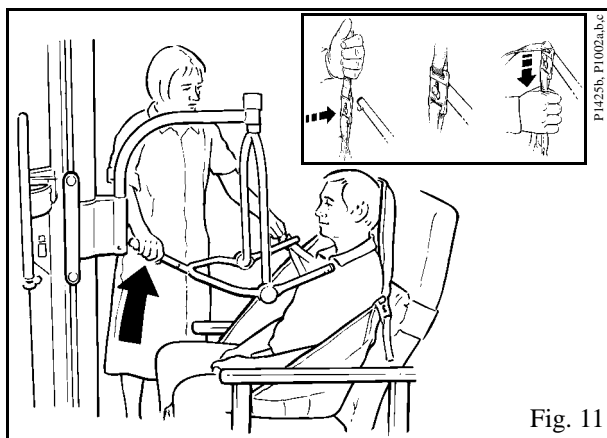
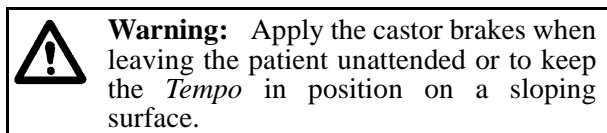

Fig. 11



**Warning:** Apply the castor brakes when leaving the patient unattended or to keep the *Tempo* in position on a sloping surface.

Press down on the positioning handle of the spreader bar and attach the leg strap attachment clips. (See fig. 12).

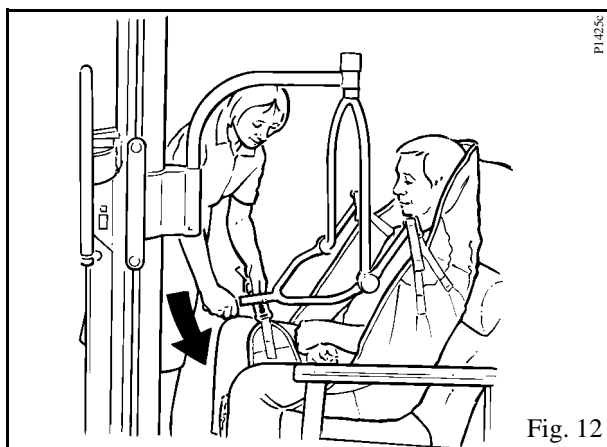

Fig. 12

If necessary, lower the spreader bar using the handset control, being careful not to lower it onto the patient, although if this should happen inadvertently, there is a built in cut-out device which will prevent any further downwards movement. Do not continue to press the handset lowering button.

- **Note:** If the handset button is released during lifting or lowering, powered motion will stop immediately.



**Warning: IMPORTANT:** Always check that the sling attachment clips are fully in position before and during the lifting cycle, and in tension as the patient's weight is gradually taken up.

Raise the patient by operating the handset control, move the lifter away from the chair then carefully lift the positioning handle until the patient is reclined in the sling - the head support will now come into use. (See fig. 13). This is the most comfortable position for transportation, as it reduces pressure on the thighs. The angle of recline can be adjusted for increased comfort if the patient is restless.

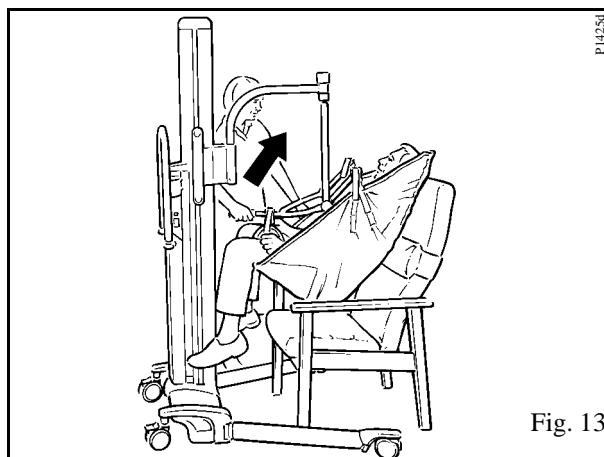

Fig. 13

Before transportation, turn the patient to face the attendant at approximately normal chair height. (See fig. 14). This gives confidence and dignity and also improves the *Tempo* mobility.

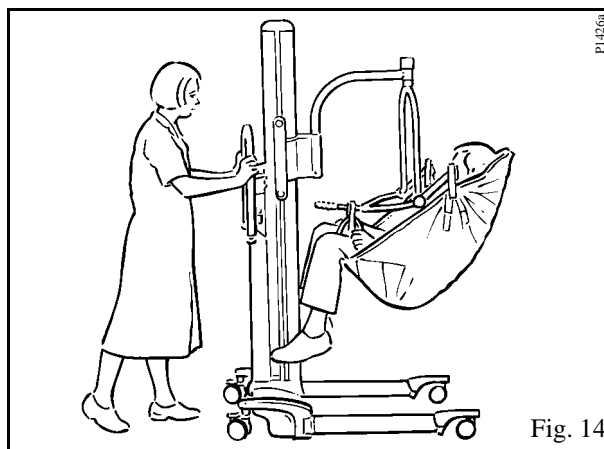

Fig. 14

Remember to release the brakes, if they have been applied, before attempting to transport the patient.

# Using your *Tempo*

When lowering the patient back into a chair - or when transferring from bed to chair - push down on the positioning handle to put the patient into a good sitting position. This avoids further lifting effort. Take care not to push down too quickly, as this may jerk the patient's head forward.



**Warning:** When lowering the lifter ensure that the patient's or attendant's legs and feet are well clear of the moving jib mounting carriage.

## To Lift from a Bed

Before lifting a person from a bed, ensure there is sufficient clearance underneath to accommodate the *Tempo* chassis legs.

Position the patient onto the sling by rolling the patient towards you then folding the sling in half and placing it behind the patient's back (see fig. 15). Position the sling carefully so that when rolled back the patient will lie centrally on the sling (see fig. 16) and check that the head support area of the sling covers the patient's neck.

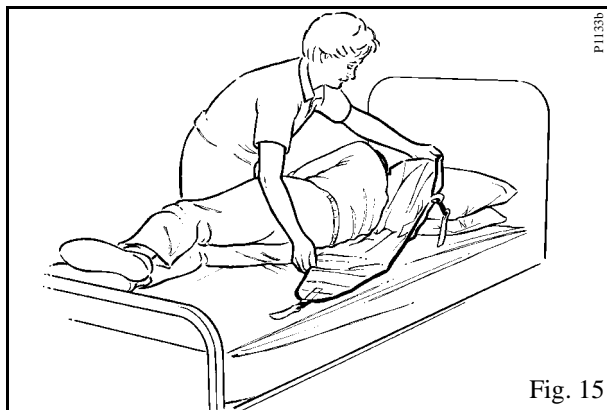

Fig. 15



Fig. 16

- **Note:** When rolling the patient back onto the sling, roll the patient slightly in the opposite direction so that the folded part of the sling can be brought out.

Alternatively, the patient can be brought into a sitting posture then position the sling as detailed in the section "To Lift From A Chair".

Approach the bed with the open side of the spreader bar towards the patient's head. (See fig. 17).

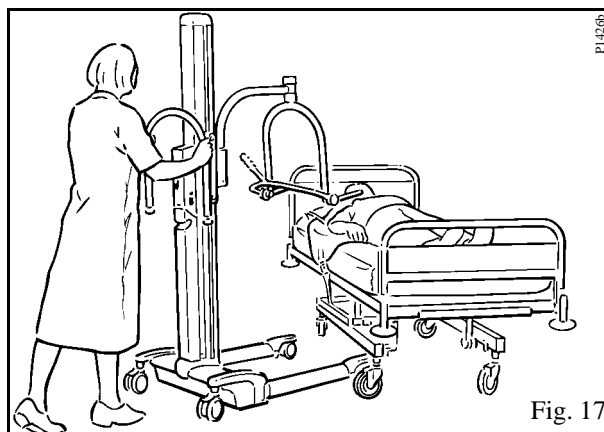

Fig. 17

Using the adjustable width chassis, it is possible to make adjustments to chassis leg widths to assist manoeuvrability around obstructions, for example, bed legs.

Position the *Tempo* so that the spreader bar is just above, and centrally situated over the patient.



**Warning:** Care must be taken not to lower the spreader bar onto the patient.

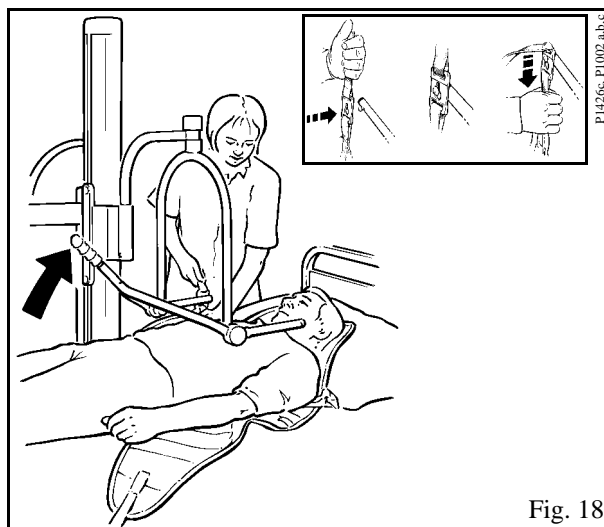

Fig. 18

# Using your *Tempo*

Using the positioning handle, tilt the spreader bar until the shoulder attachment points can be connected to the sling shoulder strap attachment clips. (See fig. 18).

Press down on the positioning handle until connection of the sling leg pieces is possible. (See fig. 19) the leg pieces must be brought under the thighs to connect up, this may involve lifting one leg at a time to connect up. You may need to lower the spreader bar a little more, using the handset control.

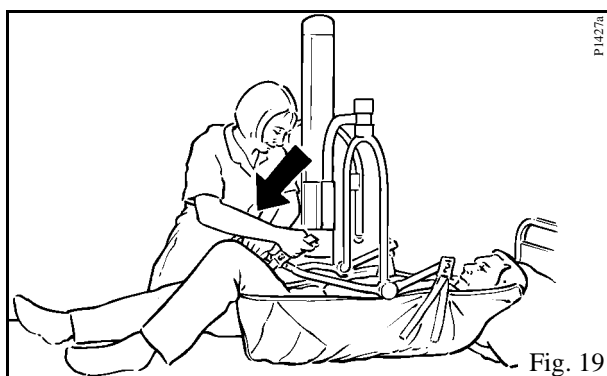

Fig. 19

When lifting from the bed, some attendants prefer to connect the leg pieces first. This particularly applies to patients with large thighs. In this case, raise the hip and knee into maximum flexion, and attach the leg strap attachment clips, then tilt the spreader bar towards the shoulders for connection.



**Warning: IMPORTANT:** Always check that the sling attachment clips are fully in position before and during the commencement of the lifting cycle, and in tension as the patient's weight is gradually taken up.

Lift the patient using the handset control, and adjust to a comfortable position for transfer. (See fig. 20). The specially designed sling together with its' integral head support, enables one person to carry out the complete lifting function without additional help.

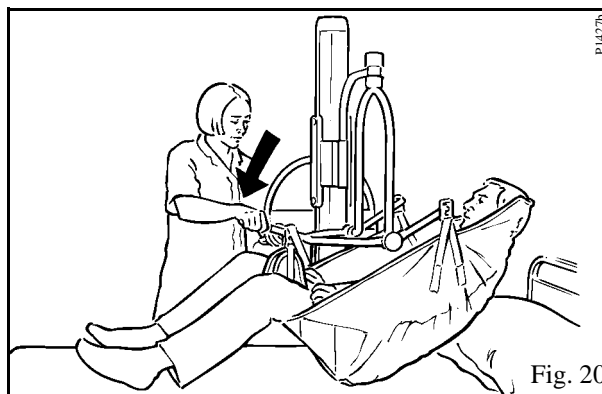

Fig. 20

If returning the patient to a bed, move into the desired position above the bed adjusting the sling position as necessary, and then lower using the handset control.



**Warning:** When lowering the lifter ensure that the patient's or attendant's legs and feet are well clear of the moving jib mounting carriage.

Only when the patient's body weight is fully supported by the bed may the sling leg connection clips be detached, followed by the shoulder connections.

Move the *Tempo* away before removing the sling from under the patient. If transferring the patient to a chair refer to the section "To Lift from a Chair".

## *To Raise from the Floor*

Put the sling around the patient as before, by using the rolling or sitting up method. Depending on circumstances, space and/or position of patient etc. approach the patient with the open part of the chassis. Open the chassis legs if necessary, and lift the patient's legs over the chassis as shown in figure 21.

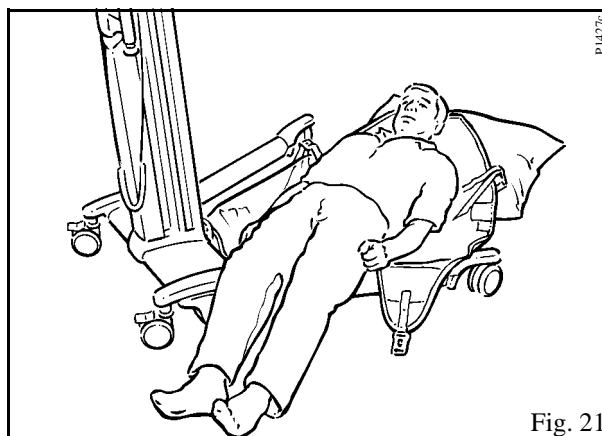

Fig. 21



# Using your *Tempo*

The patient's head and shoulders could be raised on pillows for comfort, if required, but this is not essential when connecting up the sling to the spreader bar.

With the open part of the spreader bar pointing down towards the shoulders, attach the shoulder strap attachment clips, as shown in figure 22 and inset.

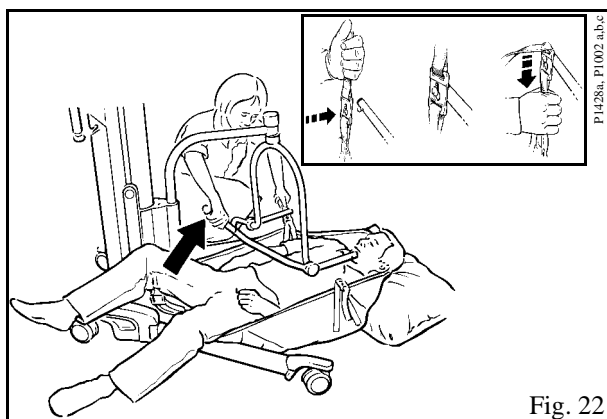

Fig. 22

Once connected, raise the hip and knee into maximum flexion, and push down on the positioning handle in order to connect the leg strap attachment clips as shown in figure 23. This will have the effect of raising the patient's head and shoulders slightly.

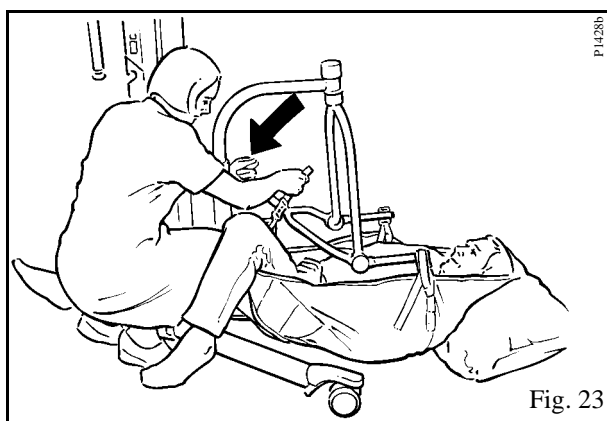

Fig. 23



**Warning: IMPORTANT:** Always check that the sling attachment clips are fully in position before and during the commencement of the lifting cycle, and in tension as the patient's weight is gradually taken up.

When lifting from the floor, some attendants prefer to connect the leg pieces first. This in particular applies to the very large patient with large thighs. In this case, raise the hip and knee into maximum flexion, and attach the leg straps first, then tilt the spreader bar towards the shoulders to enable the shoulder straps to be connected.

When all the straps have been properly connected, raise the patient from the floor in a semi-recumbent position. Supporting the head can be comfortable and reassuring for the patient. Once raised from the

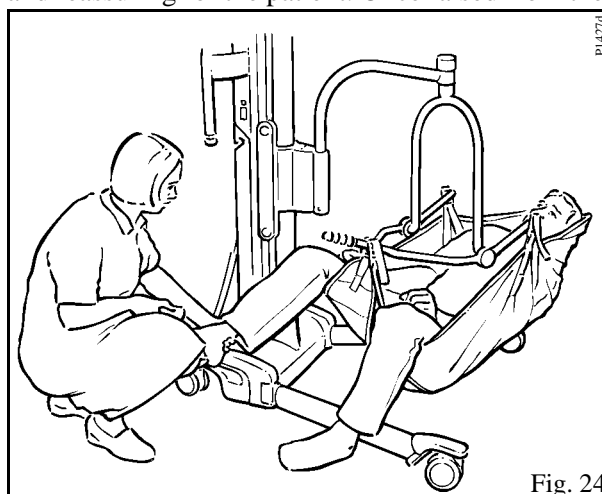

Fig. 24

floor, ensure the patient's legs are clear of the chassis before continuing to lift. (See fig. 24). The leg sections of the sling will tend to be fairly high in the crotch, so straighten them out for added comfort. The patient may be positioned in a chair, or placed onto a bed. If the patient is prone to extensor spasm, he/she may be lifted by the Tempo, but special attention should be paid to supporting the legs during the early part of the lift.

When lifting patient's with leg amputations, use the double amputee sling (available as an accessory from ARJO Ltd). This sling is specially designed to accommodate the differing patient centre of gravity.



**Warning:** When lowering the lifter ensure that the patient's or attendant's legs and feet are well clear of the moving jib mounting carriage.

Transportation of a patient should always be done with the chassis legs parallel (closed) manoeuvrability will be easier, especially through doorways, with the chassis legs closed. The patient should be positioned facing the attendant. (See fig. 17). Apply the chassis brakes if leaving the patient unattended.

# Using your *Tempo*

## At the Toilet

For toileting a patient, use the toilet sling with head rest. The toilet sling is fitted in a similar manner to the standard four point sling, except, the sling is not taken to the base of the patient's spine, but fitted with the top of the head support area of the sling level with the top of the patients head as a guide to positioning. (See fig. 25)

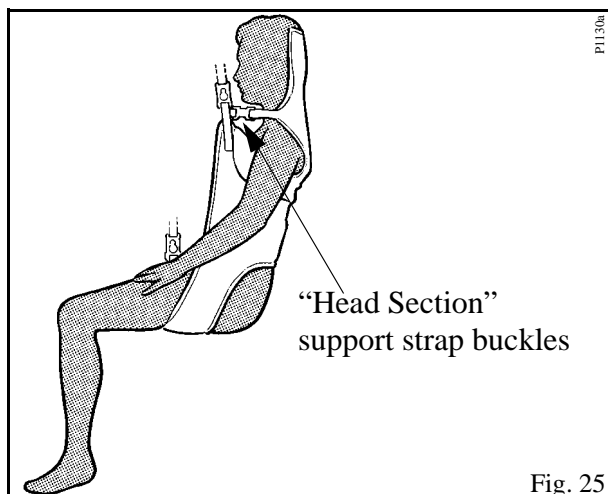

The ARJO toilet sling has been specially designed to help support patients whilst toileting.



**Warning:** It is essential to familiarise yourself with the correct method of use before any attempt is made to lift a patient.

Always ensure that the patient has sufficient trunk and head self-control to be safely lifted in the toilet sling. If in any doubt use the standard type sling.

To provide the best possible access when toileting the sling has a wide commode opening and because of this it is essential that:-

- (a) The correct size sling is chosen, relative to the weight and height of patient and
- (b) both of the patient's arms are positioned outside the sling, over the padded areas but under the "head section" support straps' (See fig. 25) this will help prevent the patient from sliding through the sling.

- **Note:** It is advisable to release the "head section" support strap buckles prior to fitting the sling, once the sling is around the patient, reconnect the support strap buckles ensuring the patient's arms are positioned over the sling.



**Warning:** Always ensure that the patient, when suspended, is in an upright sitting position, as shown in figure 25.

When used in accordance with these instructions the toileting sling provides a very effective method of toileting dependent patients.

Once the patient has been lifted and transported to the toilet, position the lifter so that the patient is positioned above the toilet seat.



**Warning:** When lowering the lifter ensure that the patient's or attendant's legs and feet are well clear of the moving jib mounting carriage.

Apply the chassis brakes.

Unbutton and / or remove the patients garments lower the patient to a comfortable sitting position.



**Warning:** Always use the toilet sling with caution, encourage the patient to hold tightly to the sling to avoid sliding out. Do not use the toilet sling for lifting and transportation apart from toilet visits.

## Powered Patient Positioning Spreader Bar (if fitted) (see fig. 26)

If your lifter has been supplied fitted with a Powered Patient Positioning (P.P.P.) spreader bar, the use of this type of spreader bar including sling positioning with patient, sling connection to the spreader bar, and patient handling, is the same as the non-powered 4 point spreader bar described previously in these instructions.

# Using your *Tempo*

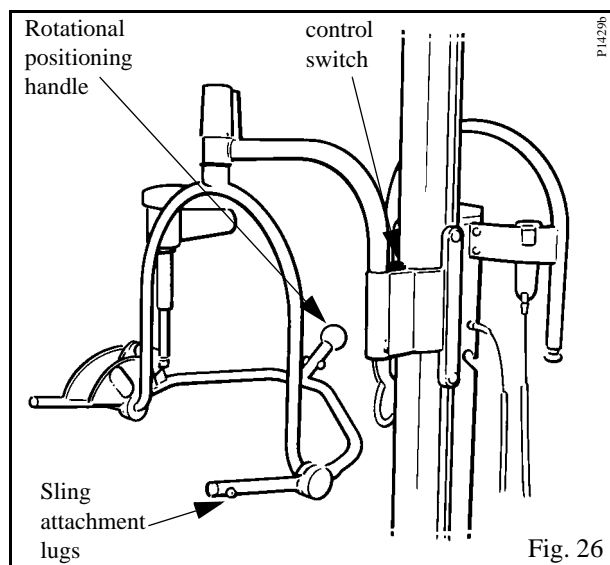

Fig. 26

The fundamental difference being, that the “P.P.P.” spreader bar has the added advantage of enabling the patient positioning manoeuvre to be performed with minimal physical effort by the attendant.

Rotation of the P.P.P. spreader bar is manual and is the same as the manual patient positioning spreader bar.



**Warning:** Before using your lifter when fitted with the P.P.P. spreader bar, familiarise yourself with the various parts as illustrated in figure 26, then read and thoroughly understand the following operating instructions.

The P.P.P. spreader bar must be used in accordance with the following instructions and in conjunction with the operating instructions previously described for the manually operated (non-powered) four point spreader bar.

The lifting capacity of the lifter when fitted with the P.P.P. spreader bar remains the same as the non-powered patient positioning spreader bar version.

The (P.P.P.) is fully waterproof and is classified by ARJO as a wet environment unit and has a blue and white circular label to qualify this, attached. (See “Labels” Section). This label signifies that the lower end of the unit may be immersed in bath water, or used for showering.

When ready to perform the patient positioning function (as described previously) operate the P.P.P. control switch (see fig. 27) to achieve spreader bar movement in the required direction. A label situated near the switch is for easy direction recognition (see also “labels” section).

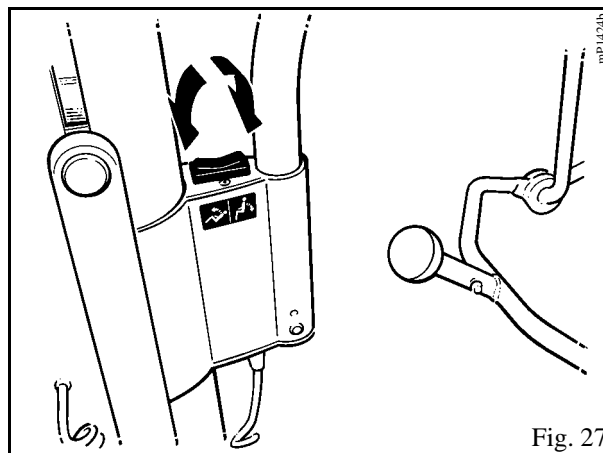

Fig. 27

Powered movement will continue until the limit of travel has been reached, or until pressure is released from the control switch.



**Warning:** To stop any powered movement, release pressure from switch.

The spreader bar will remain firmly in position, once powered movement has ceased.



**Warning:** Before and during operating the powered patient positioning spreader bar, ensure all obstructions are well clear of the spreader bar, support frame and jib.

## *Powered patient positioning function cut out fuse*

If a solid obstruction is encountered accidentally during upward or downward movement then an automatic cut out fuse will operate to protect the system. The fuse will reset quickly once powered movement has ceased, the obstruction or lifter should be moved to avoid this re-occurring. If the patient positioning function cut out fuse operates again, withdraw the lifter from use and contact ARJO Service department.

# Using your *Tempo*

---

## *Care Of Your Powered Patient Positioning Spreader Bar*

For general care refer to the “Care Section”. Refer in particularly to paragraphs relating to cleaning, plastic parts, labels, etc.



**Warning:** Apart from cleaning no user maintenance is required, but some components may need to be serviced or replaced periodically. This should be carried out by an ARJO qualified service engineer. For more information contact ARJO or their approved distributor.

## *Patient Scale (if fitted)*

See separate supplementary operating instructions.

# Lifter battery charging

The *Tempo* incorporates a battery discharge indicator, situated on the rear side of the controls console (see fig. 1). The display shows ten levels of battery state ranging from fully charged on the right to very low on the left (green, through amber to red)



**Danger:** The charger is for indoor use only.

Only use the charger unit in a dry environment, do not use it in the bathroom.

Do not expose the charger unit or battery pack to rain or spray and do not immerse in water.

Only use the ARJO battery that is supplied to be used with the Tempo

The battery charger is for use only with ARJO supplied batteries that are to be used with the Tempo

The battery charger is for use with sealed lead acid batteries only.

Under no circumstances should the charger be used to attempt to recharge non-rechargeable batteries.

Do not attempt to open or tamper with the charger unit in any way, for any repair the charger must be sent to the manufacturer.

The mains electricity socket must be easily accessible. Should a faulty condition occur switch off and remove the connection plug from the socket.

Only use ARJO components that have been specifically designed for the purpose when charging batteries.



**Warning:** To avoid overheating, the charger must not be covered whilst in use.

No smoking or naked flames in battery vicinity.

Do not expose the charger unit to dust.

Do **NOT** charge batteries in a sealed container.

Do **NOT** place batteries near, or dispose of, in a fire.

Do **NOT** short circuit a battery.



**Warning:** Do **NOT** store batteries at temperatures in excess of 60°C (140°F).

Do **NOT** crush, puncture, open, dismantle or otherwise mechanically interfere with batteries.

Should the battery casing become cracked, and electrolyte come into contact with skin or clothing, wash immediately with water.

When disposing of batteries, contact the appropriate local authority for advice.

The abbreviation "Pb" shown adjacent to the recycling and trash bin symbols on the battery pack label is the element symbol for lead, and indicates that the battery contains lead and therefore should not be disposed of in the normal manner but must be recycled.

For more details of caring for your lifter battery refer to the 'Battery Care' literature, ARJO Part No. KDX01660.GB.

- **Note:** *The battery discharge indicator has an energy saving function which automatically switches off the display if a function button has not been operated for at least 30 seconds. The moment a button is pressed to operate any function the display will re-start.*

It is recommended that the battery is removed from the lifter and recharged when the display reaches the yellow range, but lifting is possible until the display shows the red flashing light, at this point, the battery must be recharged as soon as possible.

Recharging the battery pack before it reaches a low state of battery charge or certainly totally discharged will prolong its life.

Your lifter is fitted with an audible warning device this will sound when the battery discharge indicator reaches the red light range. The audible warning will sound for approximately thirty seconds and will start when a function button is pressed. Pressing the emergency stop button will temporarily silence this function, removing and replacing the battery with one fully charged will silence the alarm until low battery condition re-activates it.

# Lifter battery charging

To ensure the *Tempo* is always ready for use, it is recommended that a freshly charged battery pack is always available. This is achieved by having additional battery packs available and keeping one on charge while the other is in use.

It may be considered good protocol to have a freshly charged battery ready for the start of every work shift.

- **Note:** *Whichever level the indicator has reached, once a fully charged battery is re-inserted into the lifter, the display will return to the green fully charged position, but if a partially charged battery is re-inserted, the level at which the indicator had reached will remain, even though the recently inserted battery may be in a better state of charge than indicated. To achieve a true indication of battery state a fully charged battery must be inserted into the lifter to reset the indicator.*

Place the battery pack on charge as follows:



**Caution:** Ensure the mains power to the charger unit is switched off before connecting the battery.



**Warning:** Always ensure the cable connection plugs that fit into the charger and into the battery are fully inserted before switching on mains electricity.

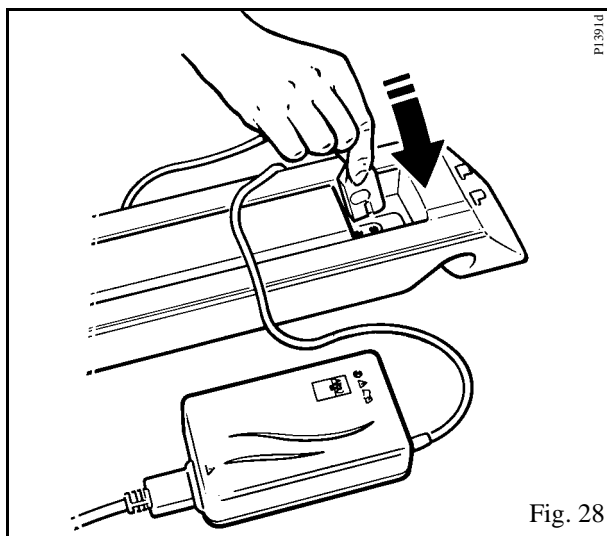

- **Note:** *The cable that connects the main electricity supply to the charger is supplied as a detachable item. If using the battery charger for the first time or if the cable has been unplugged from the charger, connect the cable fully into the charger before connecting to the mains electrical.*

When the LED on the battery discharge indicator display amber, complete your lift cycle then take the lifter to a convenient situation and remove the battery pack by holding the grip position of the battery and pressing the release catch situated above, pivot the battery away and lift clear. Take the battery to the battery charger unit and ensure the battery is positioned securely then insert the battery connector from the charger into the corresponding connector in the back of the battery (see fig. 56), switch on mains power. An orange light will be displayed on the charger unit when the battery is totally discharged. This will change to a yellow light as the battery approaches full charge capacity, finally changing to a green light when the battery is fully charged.

A discharged battery should be left approximately 8 hours to totally recharge (See also ARJO Battery Care document).



**Warning:** Hold the pack firmly to ensure it does not drop and become damaged, or cause personal injury.

- **Note:** *The battery pack may be left connected to the charger unit when it is fully charged without being damaged by overcharging, this will also ensure the battery is kept fully charged.*



**Caution:** Always disconnect the mains supply before disconnecting the battery charger unit.

When the battery pack is fully charged, disconnect the mains power, remove the battery pack from the charger, and insert it back into the *Tempo* battery position.

Ensure the green reset button (situated on the rear of the mast) is pressed in (see fig. 1).

The *Tempo* is now ready for use.

# Care of your Tempo

---

How often the following actions are taken depends on how often the equipment is used.

Unless otherwise stated, before each and every use follow the cleaning, care and inspection procedures described in this section.

## *Sling care and cleaning:-*



**Warning:** The slings should be checked before and after using with each patient and if necessary washed according to instructions on the sling, This is especially important when using the same equipment for another patient, to minimise the risk of cross infection. Also refer to sling instruction sheet MAX.01510.INT.

With regard to laundering, slings should not be classified as linen, but as an accessory to a patient transfer lifter and therefore classified as a medical device. Slings should be cleaned and disinfected only in strict accordance with the manufacturers instructions.

Mechanical pressure should be avoided during the washing and drying procedure e.g. rolling or pressing, as these can damage parts vital to the safe and comfortable operation of the sling.

Washing and drying temperatures must not exceed 80°C (176°F). Wash using normal detergents, do not iron. Also refer to Sling Instruction sheet MAX.01520.INT.

It is essential that the sling attachment cords, the slings, their straps and attachment clips are carefully inspected before each and every use. If the slings, cords or straps are frayed, or the clips damaged, the sling or attachment cord should be withdrawn from use immediately and replaced.

## *Lifter care and cleaning:-*



**Warning:** It is recommended that patient lifters, equipment, accessories are regularly cleaned and/or disinfected between each patient use if necessary, or daily as a minimum. If the lifter and/or equipment needs cleaning, or is suspected of being contaminated, follow the cleaning and/or disinfection procedures recommended below, before re-using the equipment.

For cleaning your lifter, equipment and accessories wipe down with a damp cloth using warm water to which a disinfectant/cleaner has been added e.g. “ARJO CLEAN” - disinfectant/cleaner or equivalent

- **Note:** “ARJO CLEAN” - disinfectant cleaner is available from ARJO Ltd. or their approved distributors.



**Caution:** Do not over wet areas of the product which could cause problems with electrical components or internal corrosion.

If a hot air dryer is used to dry the lifter, the temperature must not exceed 80°C (176°F)

Do not use petroleum based solvents or similar, since this may damage plastic parts.

All units classified as ARJO wet environment products (eg. P.P.P. spreader bar) if immersed in chlorinated, salt or mineral water should be cleaned with fresh water and dried after use.



**Warning:** For disinfection of contaminated lifters, equipment and accessories, use the preferred method of wiping the product completely with “hard surface disinfectant wipes” that are supplied impregnated with a 70% v/v solution of Isopropyl Alcohol.

# Care of your *Tempo*

- **Note:** A rubbing action will be necessary when using the wipes to promote effective disinfection of the surfaces.



**Warning: IMPORTANT:** Cleaning and disinfection products must be used in accordance with the manufacturers instructions and suitable eye, hand and clothing protection must be worn at all times when handling disinfectants.

- **Note:** 70% v/v Isopropyl Alcohol wipes have been proved to be effective against MRSA and several other micro-organisms under light soiling conditions.

*The following checks should be carried out daily.*

Ensure that the battery pack is always in a good state of charge.



**Warning:** Ensure that the castors are firmly secured to the chassis.

Carefully inspect all parts, in particular where there is personal contact with the patient's body, ensure that no cracks or sharp edges have developed which could injure the patient's skin or become unhygienic.

Check that all external fittings are secure and that all screws and nuts are tight.

Ensure that all instruction labels are firmly attached and in good readable condition.

## *Periodic Testing*

To be carried out at weekly intervals.

Periodic testing of the operational functions is advisable from time to time to ensure everything operates satisfactorily.

**Test for full and efficient movement of the lift / lower mechanism:-** Raise and lower the jib using the control handset, test also with dual switch panel.

**Automatic Stop Function:-** With the jib well above its lowest position and the lifter positioned

over an empty bed, use the handset control to lower the jib onto the bed. As the jib lowering is restricted, the motor will stop, release the control handset lower button after a second or two. Raise the jib using the control handset, then repeat the test using the dual switch panel, this check is for the correct functioning of the automatic stop.

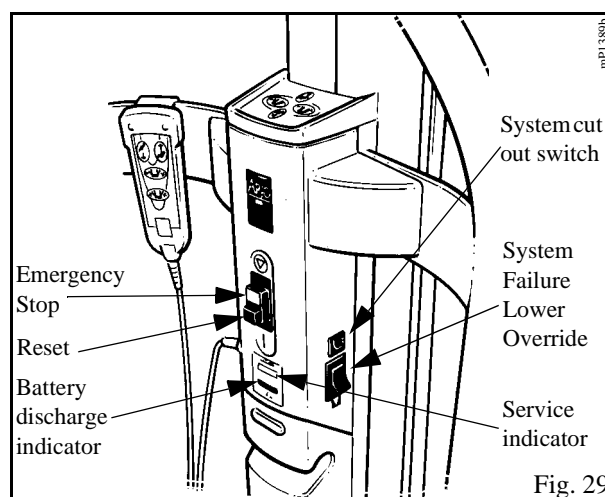

**Emergency Stop:-** Test the emergency stop facility by operating the control handset to lift or lower the jib, and whilst operating, press in the emergency stop button (see fig. 29). Powered movement should stop immediately.

Reset to normal function by pressing the green reset button (see fig. 29). Repeat this test using the dual switch panel, reset to normal function. Repeat for chassis legs opening / closing function, and reset the button.

**System Failure Lower Override:-** Test this function simply by ensuring the jib is well above its lowest position then operate the system failure lower override switch (see fig. 29). The jib will lower without the need to operate the control handset or dual control panel. The lower override facility will still operate even with the handset control cable unplugged.

**Adjustable Width Chassis Function:-** Open and close the chassis legs using the control handset and dual switch panel, to check for full and efficient movement.

**General lifter Condition:-** A general visual inspection of all external parts should be carried out, and all functions should be tested for correct operation, to ensure that no adverse damage has occurred during use.



# Care of your *Tempo*

---



**Warning:** If in any doubt about the correct functioning of the *Tempo*, withdraw it from use and contact ARJO Service Department.

## *Servicing Advice*



**Warning:** ARJO recommend that the *Tempo* is maintained at regular intervals, see ARJO *Tempo* Preventative maintenance schedule (ARJO Literature Part No. PMS018/*Tempo*)

With regular use the following items are subject to wear:- Slings, batteries, straps, castors. These items must be regularly checked as described previously, and replaced as necessary.



**Warning:** UK LIFTERS ONLY: Important legislation came into force on 5th December 1998, which has an impact on the schedule of service for your patient lifter(s), variable height baths and other raising and lowering equipment. The Lifting Operations and Lifting Equipment Regulations (LOLER) 1998 and The Provision and Use of Work Equipment Regulations (PUWER 98) must be satisfied by the duty holder. A scheme of six monthly thorough examinations has been devised to comply with the law and details can be obtained from ARJO Service UK

Parts list and circuit diagrams are available from ARJO or their approved distributors on request.



**Warning:** Spare parts, if required are available from ARJO or their approved distributors.

Special tools are required for certain component replacement



**Warning:** The simplest, safest and most effective way to maintain your product in good working order, is to have it methodically and professionally serviced by an ARJO approved engineer using ARJO approved spare parts.

For information on service and maintenance contracts, please contact your local ARJO distributor.

# Labels

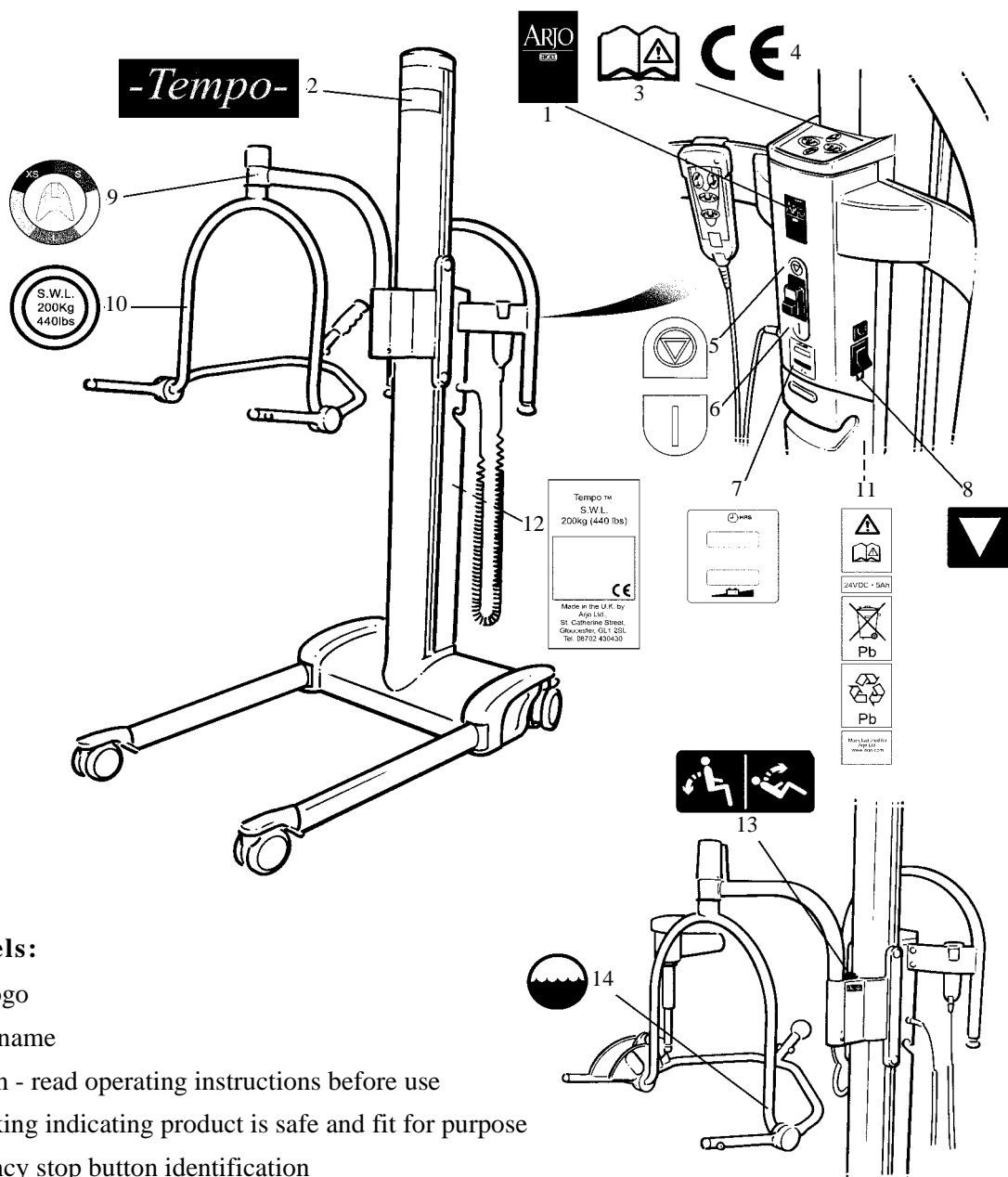

## Key to labels:

1. ARJO logo
2. Product name
3. Attention - read operating instructions before use
4. CE marking indicating product is safe and fit for purpose
5. Emergency stop button identification
6. Reset button identification
7. Service indicator/battery condition indication
8. System failure lower override control identification
9. Sling size guide
10. Safe working load of individual component
11. Battery instruction/recycling information
12. Safe working load of lifter
13. Patient positioning
14. ARJO wet environment product identification

# Technical Specification

---

## Component Weights

	kg	lbs
<i>Tempo</i> (complete - less battery) with standard jib and 4 point spreader bar .....	52.5	(115.7)
<i>Tempo</i> (complete - less battery) with P.P.P. 4 point spreader bar) .....	59.2	(130.5)
'V' opening chassis (only) .....	22.9	(50.5)
Battery pack.....	4.9	(10.8)

## Electrical

Battery type and part number .....	(Rechargeable - lead acid) KPA0100
Battery capacity .....	5Ah
Battery charger part number .....	KPA0101**
	(Note: ** indicates relevant country code)
Handset - Protection class .....	IP67
Lifter nominal voltage .....	24V DC

Medical Equipment:- type  protection against electrical shock in accordance with IEC 601-1)  
ARJO patient handling products meet the requirements of Electromagnetic Compatibility (EMC) as stated in clause 12.5 of the Medical Devices Directive 93/42/EEC

	Duty cycle	Max volts	Max amps
Mast Lift Actuator .....	15% (9 min/hr)	24	-
'V' Chassis Actuator .....	10% (6 min/hr)	24	4.5

## Environment

Air humidity/storage .....	80% @ 20°C (68°F)
Usage temperature range (ambient) .....	+5°C (41°F) to +35°C (95°F)
Optimum usage temperature (ambient).....	+20°C (68°F) to +25°C (77°F)
Storage and transportation temperature (ambient) .....	-10°C (14°F) to +45°C (113°F)

# Technical Specification

---

The *Tempo* should not be loaded with a weight in excess of the lowest rated attachment fitted (see table below for lifter and attachments maximum lifting capacities).

## MAXIMUM CAPACITIES OF *TEMPO*

All slings (except Extra Extra Large - XXL)	-	190kg	(420lbs)
Extra Extra Large sling - XXL	-	200kg	(440lbs)
Lifter + Dedicated jib + 4 point spreader bar	-	200kg	(440lbs)
Lifter + Dedicated jib + 4 point P.P.P. spreader bar	-	200kg	(440lbs)
Lifter + 200mm Extended dedicated jib + 4 point spreader bar	-	130kg	(286lbs)
Lifter + Dedicated jib + 4 point spreader bar + scale	-	200kg	(440lbs)
Lifter + Dedicated jib + 4 point P.P.P. spreader bar + scale	-	200kg	(440lbs)

The capacities given are correct for the lifter configurations listed, but some accessories/additional/optional sub assemblies may reduce the maximum capacity. Always refer to the maximum weight limit printed on the label fixed to the lowest rated fitted attachment.

# Technical Specification

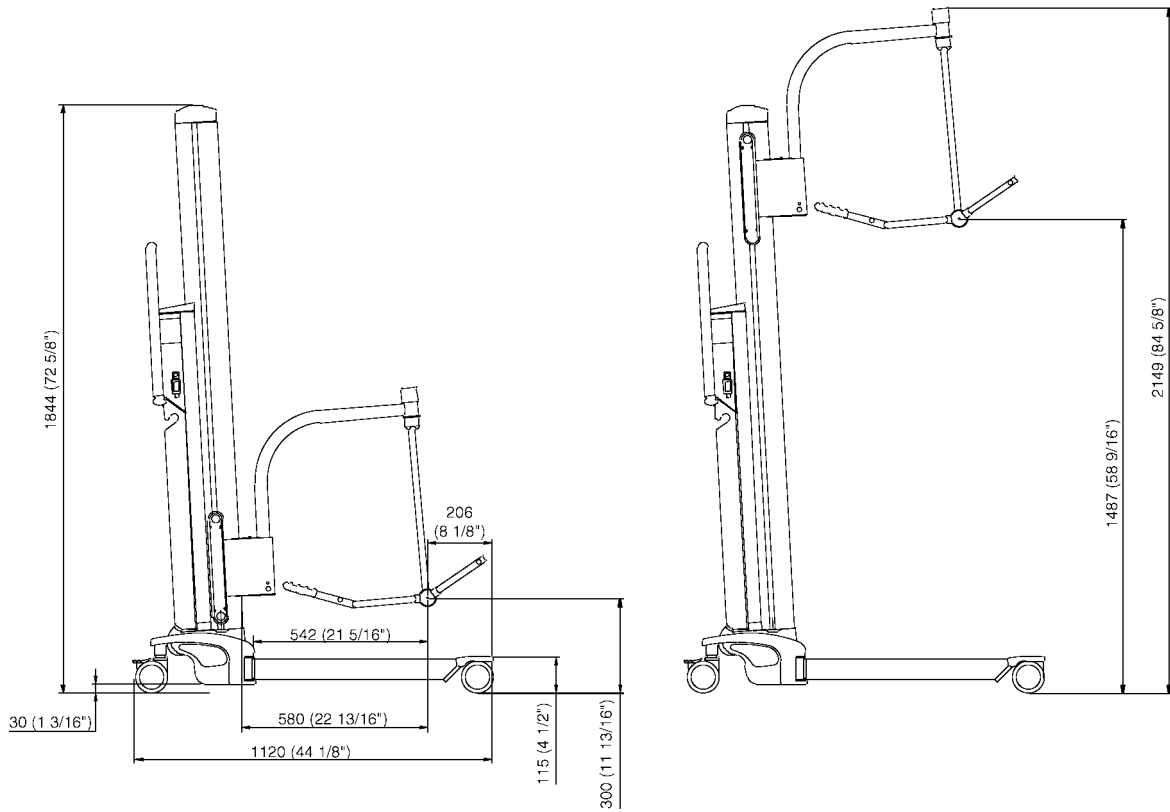
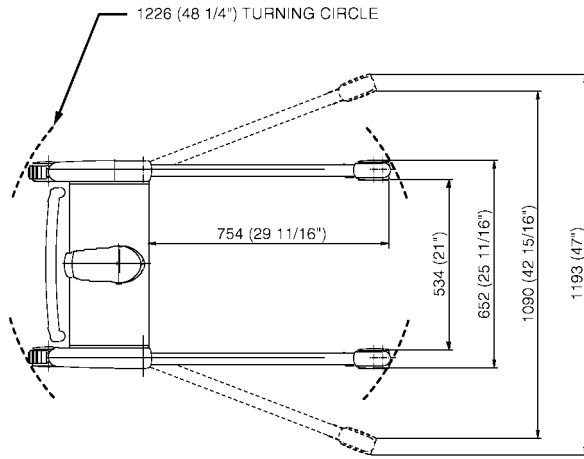

Dimensions in millimetres (equivalent in inches)

# Notes

---

# Notes

---

**AUSTRALIA**  
Arjo Hospital Equipment Pty. Ltd.,  
154 Lytton Road  
Bulimba  
Brisbane  
QLD, 4171  
Tel. (61) 7 3395 6311  
Fax. (61) 7 3395 6712

**BELGIQUE / BELGIË**  
Arjo Hospital Equipment nv/sa  
45, avenue de l'europe  
Eurocit  
F-59435 RONCQ CEDEX  
FRANCE  
Tel: +33 3 20 28 13 13  
Fax: +33 3 20 28 13 14  
Email: info@arjo.be

**CANADA**  
Arjo Canada Inc.  
1575 South Gateway Road  
Unit C  
Mississauga, ONTARIO  
L4W 5J1  
Tel. 1 800 665 4831  
Fax. 1 800 309 1116

**ĚESKÁ REPUBLIKA**  
Arjo Hospital Equipment s.r.o.  
Strmá 35  
CZ-616 00 BRNO  
Tel. 05 754 252  
Fax. 05 412 13550

**DANMARK**  
Getinge-Arjo A/S  
Firskovvej 23  
DK-2800 KGS Lyngby  
Tel. 45 93 27 27  
Fax. 45 93 41 20  
Getinge.arjo@getznet.dk

**DEUTSCHLAND**  
Arjo Systeme für Rehabilitation GmbH  
Rudolf-Diesel-Strasse 5  
65719 HOFHEIM-WALLAU  
Tel. 6122 8040  
Fax. 6122 804160  
E-Mail : info@arjo.de  
www.arjo.com

**ESPAÑA**  
Arjo SPAIN, S.A.  
Vallespir, 13  
08970 Sant Joan Despi.  
Barcelona  
SPAIN  
Tel. 00 34 93 477 3733  
Fax. 00 34 93 477 3732

**FRANCE**  
ARJO Equipments Hospitaliers sa  
45, avenue de l'europe  
urocit  
F-59435 RONCQ CEDEX  
FRANCE  
Tel: +33 3 20 28 13 13  
Fax: +33 3 20 28 13 14  
Email: info@arjo.be

**GREAT BRITAIN**  
Arjo Ltd.,  
St. Catherine Street  
Gloucester, GL1 2SL  
ENGLAND U.K.  
Tel. (08702)430430  
Fax. (01452) 428344

**HONG KONG**  
Arjo Far East Ltd.  
1001-3 APEC Plaza,  
49 Hoi Yuen Road,  
Kwun Tong, Kowloon,  
HONG KONG  
Tel. 852 2508 9553  
Fax. 852 2508 1416

**ITALIA**  
Arjo Italia S.p.A.  
Via Della Marcigliana, 532  
(Cancello 9)  
00139 ROMA  
Tel. 06 8712 7023  
Tel. 06 8712 7025  
Fax. 06 8712 0640

**NORGE**  
Getinge-Arjo AS  
Ole Deviksvvei 4  
0666 OSLO  
Tel. 2305 1127  
Fax. 2305 1199

**NEDERLAND**  
ARJO NEDERLAND B.V.  
De Blomboogerd 8  
4003 BX TIEL  
Postbus 6116  
4000 HC TIEL  
Tel. 0344 640 800  
Fax. 0344 640 885

**ÖSTERREICH**  
Arjo GmbH  
Föhrenweg 5  
A-6065 THAUR  
Tel. 05223 493350  
Fax. 05223 49335075

**POLSKA**  
Arjo Poland Sp.zo.o.,  
ul. Walecznych 44,  
03-916 WARSZAWA  
Tel. 22 616 2916  
Fax. 22 617 7601

**SCHWEIZ / SVIZZERA**  
Arjo-Sic AG  
Wartenbergstrasse 15  
Postfach 4020  
BASEL  
Tel. 061 317 9797  
Fax. 061 311 9742

**SVERIGE**  
Arjo Sverige AB  
Box 61, 241 21 Eslöv  
Tel. 0413-645 00  
Fax. 0413-645 83  
E-post: kundservice@arjo.se  
www.arjo.com

**USA**  
Arjo, Inc.  
50 North Gary Avenue  
Roselle, IL 60172  
Tel. 1-800-323-1245  
Fax. 1-888-594-ARJO(2756)  
www.arjousa.com



[www.Arjo.com](http://www.Arjo.com)

If your country is not listed here, please contact your local distributor, or ARJO  
International AB, Box 61, S-241 21 ESLÖV, SWEDEN.  
Tel +46 413 64500. Fax + 46 413 555586.



FM 21964  
ISO 9001 • BS 5750 Part 1 • EN 29001  
ARJO Limited • GLOUCESTER • U.K.

